

Sound Logic

PC-2-Route All In One Model M2 Combo Board Rev 2 This is for Mach3 only

PC parallel port break-out board
For Mach3 OEM model which includes the
Relay board and Spindle Speed board
functions

General User's Guide

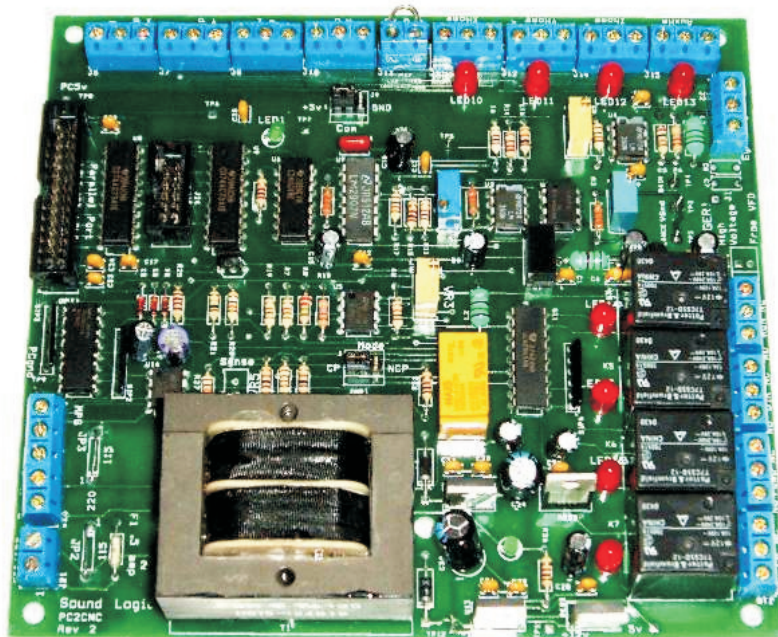

Sound Logic
James Cullins
3454 Sprindletree Dr.
Grapevine, Tx. 76051
James_cullins@sbcglobal.net

IMPORTANT INFORMATION

Copyright and Trademarks

Copyrights 2001, 2002, 2003, 2004, 2005 by Sound Logic

Disclaimers of Liability

Sound Logic or **James T. Cullins** assumes no responsibility or liability for any damage done to persons , PC, Gecko drives, equipment being controlled, loss of time or loss of work incurred while using the PC-2-Route interface board.

PC-2-Route All-in one OEM board

Rev. 2.0

Purpose:

To interface the PC parallel port to the Gecko stepper motor drives and to control four relays for powering on aux devices such as spindle, vacuum pump, and coolant pump from 115VAC.

The all-in one board also includes the spindle speed function that can control a variable frequency drive (VFD) through an optically isolated 0 to 10 volts. The board has an output for one Quadrature encoder that can be used for a manual pulse generator.

The interface uses a transformer with dual primary and secondary windings and optical-isolators to totally isolate the PC parallel port from the stepper motor power supply and the equipment being controlled. Operates on 115 volts AC or 220 volts AC (jumper selectable) 50hz or 60hz.

PC-2-Route All-in one OEM board

Rev. 2.0

Features:

●PCB:

- Fr4 material
- Solder mask on both sides
- Silkscreen (legends) on the topside.
- Plated through holes
- Inputs and outputs are optical-isolated.
- Isolated 5 volts and grounds for the PC parallel port IO.
- All outputs are buffered.
- Mode select jumper for M1 or N1 operation.

●Connectors:

. All terminals are labeled as to their function.

- 12 - screw type terminals for attaching the step, direction signals to the Gecko drives
- 12 - screw type terminals for home and limit proximity sensors or switches.
- 26 pin header for the ribbon cable to connect to the printer parallel port.
- J19 EPO connector.
- J21 220/120 power connector
- Jmp1 Mode switch to selects the mode of operation CP/NCP
- J20 MPG screw terminals
- J2 Spindle speed output
- JP1 jumper for VFD
- J16-J19 Relay outputs

Transformer:

- Dual primary windings allow operation at 115 VAC or 220 VAC. The voltage is selected using the soldered jumpers JP1 and JP2.
 - 115 VAC solder in both JP1 and JP2 jumpers.
 - 220 VAC solder one jumper between JP1-1 and JP2-1.This is indicated on the PCB.
- Dual secondary.
 - Winding one supplies 5volts via a regulator for the PC side optical-isolators.
 - Winding two supplies 5volts for the machine side optical- isolators and 12volts for the Solid State relays and proximity sensors. Both are regulated.

The grounds of these two power supplies **MUST NOT BE CONNECTED TOGETHER OR TO EARTH** doing so will destroy the isolation and expose the sensitive electronics in the PC to the inductive spikes from the motors.

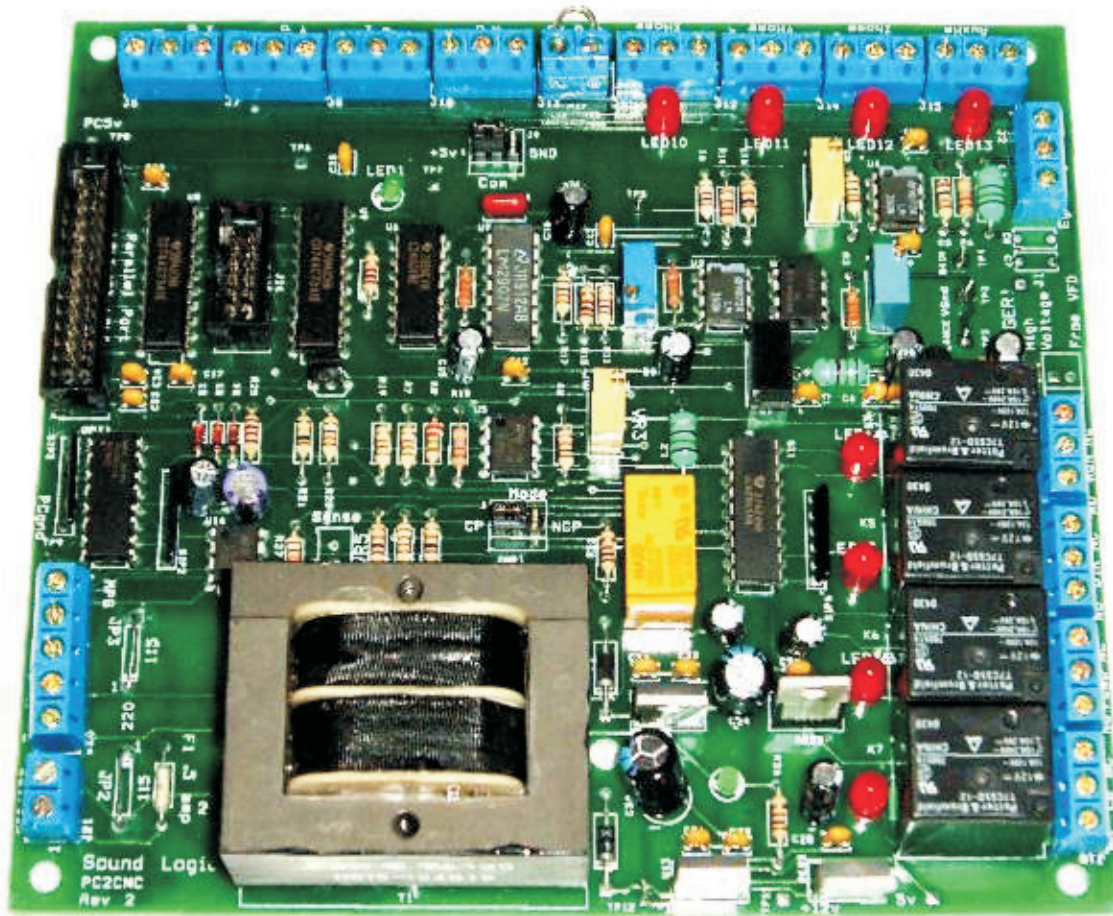

Power Supply

The power supply transformer has a dual secondary winding. One side provides a regulated 5 VDC to power the optical isolators in the Gecko drives or any other drivers that require 5 VDC. The negative side of the 5 VDC power supply is common to the common side of the PC. The PC is totally isolated from the motor and relay circuits.

The second winding provides power to a 5 VDC power supply for driving solid state relays. The 5 VDC power is also used with an optical isolator to convert the 12 VDC signal from the proximity sensors back to 5 VDC before it goes back to the PC as a limit signal.

The secondary winding also provides power to a 12 VDC regulated power supply. The 12 VDC power is used to provide power to the proximity sensors and to drive solid state relays.

Step and Direction Pin Layout

The Step and Direction signal come in from the parallel port on pins 2 through 9. They signals then go through an Optical Isolator. The Optical Isolator provides electrical isolation between the inputs from the computer and the outputs.

The outputs then go to J1 through J5. Each Step and Direction line has a LED which can be used to assist in troubleshooting.

The lights on the Step lines will seem very dim at high speeds.

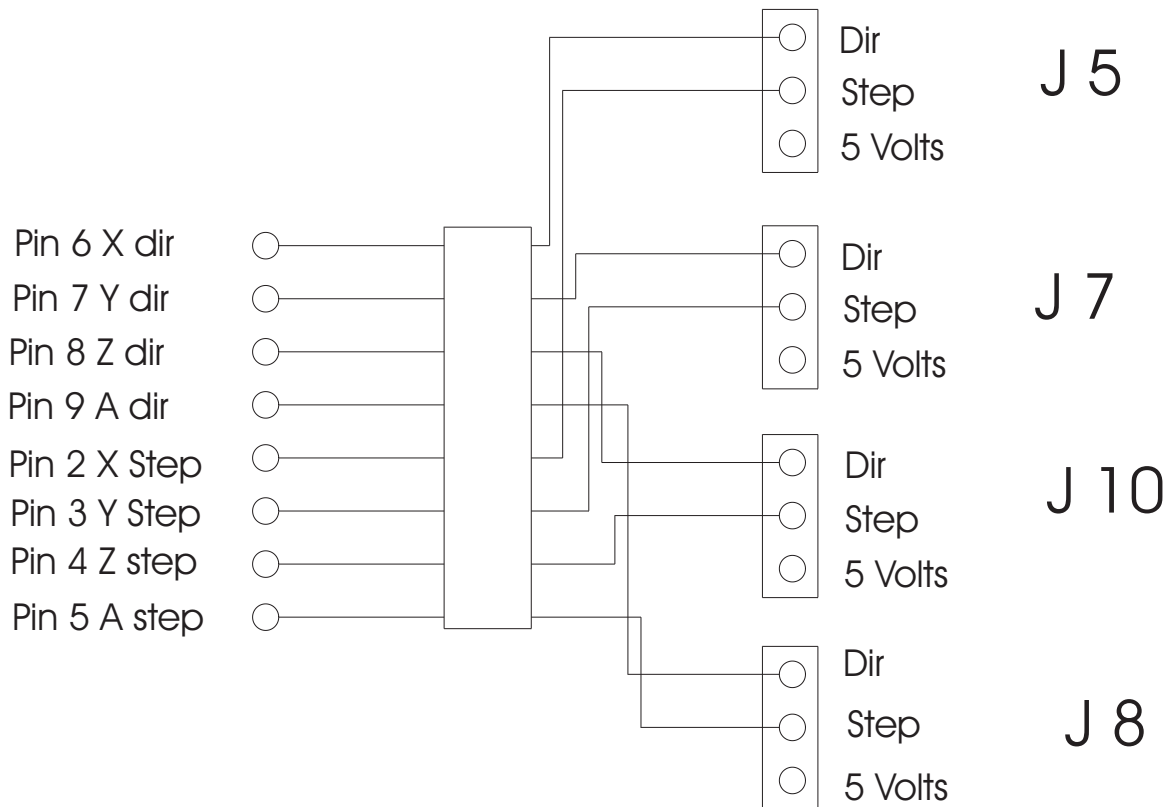

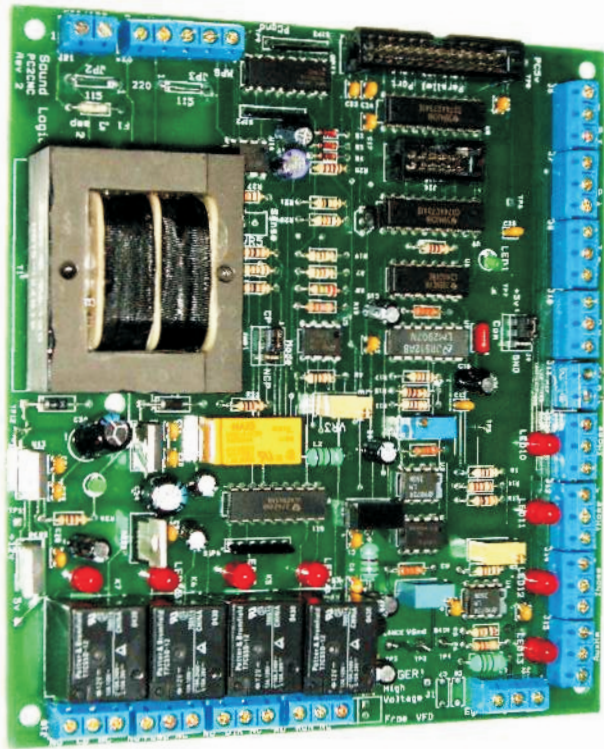

Step
&
Direction
Outputs

5 Volts to
Gecko Drives

EPO Jumper

Home
&
Limit
Inputs

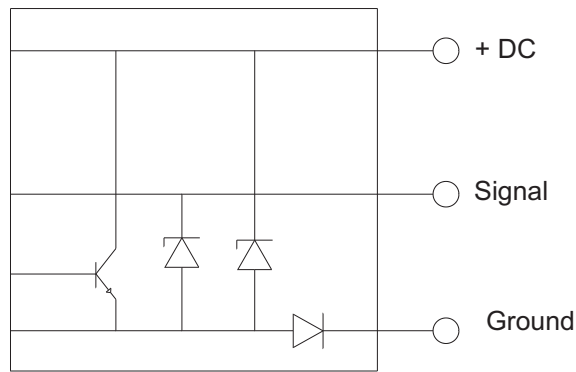

NPN Inductive Proximity Sensor

NOTE: The break-out board was designed to use either **NPN** inductive proximity sensors. A **PNP** inductive proximity sensor can be made to work by placing a 1K resistor across the signal and ground screw terminals.

Mach2 supports home and limit switches. In the picture at the top of the page, the lower 12 screw terminal are the connections for the X, Y, Z, and Aux home and limit proximity sensors.

The breakout board support inductive proximity sensors by using three screw terminals. One screw terminal is for 12 volts to power the inductive proximity sensors. One is for the signal and one is for the ground.

You can also use micro switches connected between the signal screw terminal and the ground screw terminal.

Sound Logic PC2CNC Interface

1. Four axes Step and Dir and common on 4 screw terminals.
Common is selectable from +5v to Gnd
Default is +5v
2. One Limit input for each Limit/home switch.
Inputs are optically isolated the common ground floats.
3. Four relay outputs each SPDT relay rated at 15 amps 115 volts.
 1. Spindle Run Relay
 2. Spindle Direction Relay
 3. Coolant Relay
 4. Charge pump Relay energized when Mach2 is active.
4. Optically isolated Analog 0~10v or 0~5 VDC for spindle speed via a VFD.
5. One Quadrature encoder input
You sacrifice the A and Z limit functions.
This input can be used for a spindle feedback on lathes for Threading or for a Manual Pulse Generator.
6. 115 / 220 power in
Selectable using Jp1 and JP2
7. J13 EPO input normally closed.
Wire this input through the normally closed contacts on the Emergency.
Power Off switch, or leave the jumper in place.
8. The charge pump enables the output relays and step & Dir signals only after Mach2 is running and reset has been clicked. Out 4 will be active and may be used to drive a solid state relay to activate the motor power supply. Any fault will de-activate the charge pump, remove power form the motors, and disable the step & dir signals form the drives.

Solid-state relay connection
Through an output relay.

The 12 volts and ground can be
take from any one of the limit
switch screw terminals.

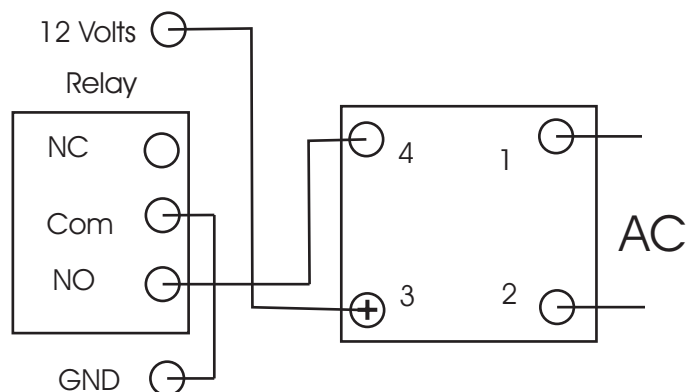

Connector Pin out.

J6 26 pin header to parallel port on the PC.

- J6 -1 Spindle step out
- 2 X step
- 3 Y step
- 4 Z step
- 5 A step
- 6 X dir
- 7 Y dir
- 8 Z dir
- 9 A dir
- 10 Estop
- 11 X Lim/home
- 12 Y Lim/Home
- 13 Z Lim/Home
- 14 Dir out relay
- 15 A Lim/Home
- 16 Coolant relay
- 17 Charge pump
- 18 to 20 PCgnd

Parallel Port connector J 6

CP/NCP J 20

J 21

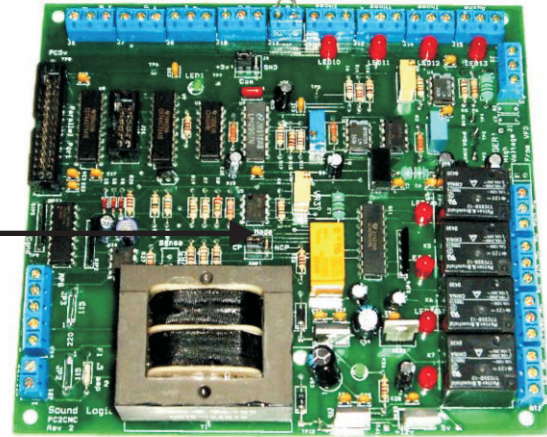

- J20 Encoder in
 - Pins 1 & 2 ground.
 - Pin 3 switch input to change between axes
 - Pin 4 B to encoder
 - Pin 5 A to encoder
 - Pin 6 +5v

The +5v and ground are from the floating ground power supply on the Interface board.

- J21 Power in.
Jp1 and Jp2 are used to set the input voltage.

For 115 VAC, Jp1 and Jp2 both have jumpers installed. (See below)

For 220 there is only one jumper (see below)

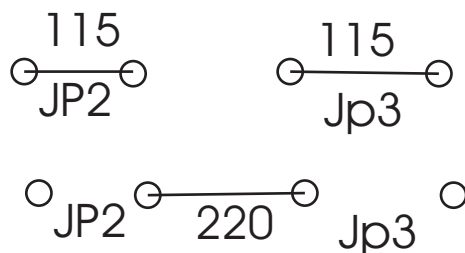

J16 Run relay

NC normally closed

Com is the center terminal

NO normally closed.

J17 DIR relay

NC normally closed FWD

Com is the center terminal

NO normally closed. REVJ18 Coolant relay

NC normally closed

Com is the center terminal

NO normally closed.

J19 Charge Pump relay

NC normally closed

Com is the center terminal

NO normally closed.

J2 VFD analog signals

Egnd earth.

Sig 0-10v

Return gnd.

JP1 mode select

Connects the com for Dir to the Normally Open on the Run relay.

This routes the gnd for the dir signal through the normally open contact of the run relay.
When the run relay closes it will select Fwd or REV determined by the Dir relay.

J11 Home / Limit switch input for the A axis
+12v is isolated and is used for powered switches such as proximity or optical switches.

Sig Low active input
Gnd (floating gnd)

J12 Home / Limit switch input for the X axis
+12v is isolated and is used for powered switches such as proximity or optical switches.

Sig Low active input
Gnd (floating gnd)

J13 Home / Limit switch input for the Y axis
+12v is isolated and is used for powered switches such as proximity or optical switches.

Sig Low active input
Gnd (floating gnd)

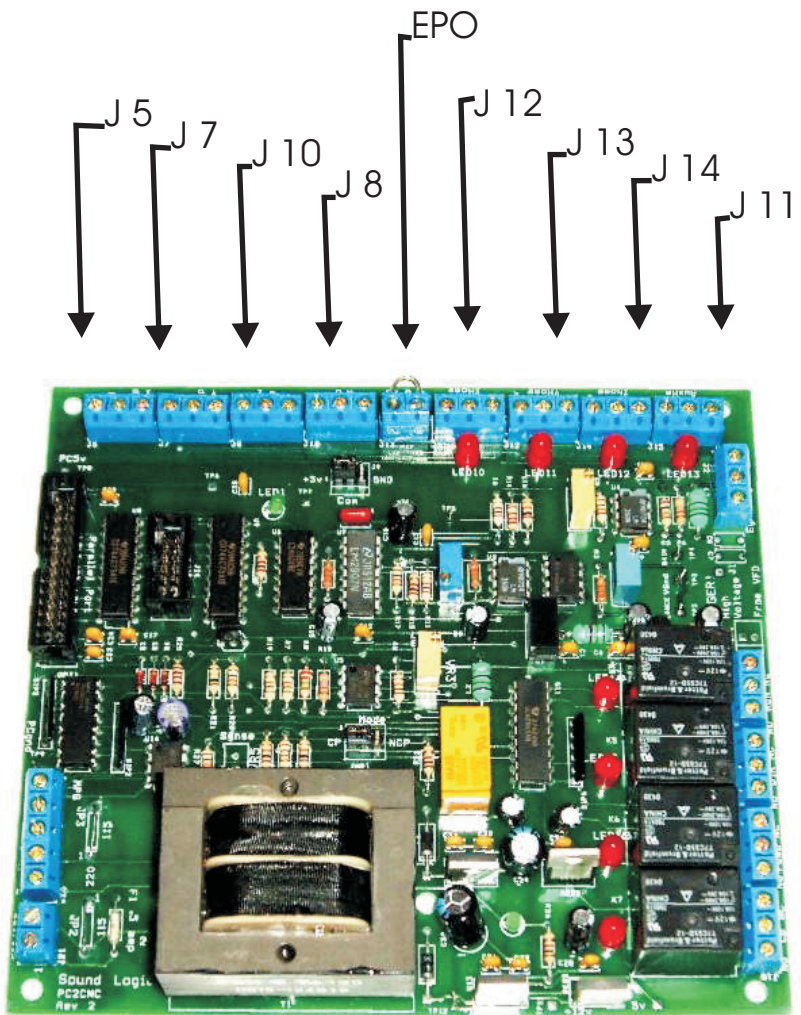

J14 Home / Limit switch input for the Z axis
+12v is isolated and is used for powered switches such as proximity or optical switches.
Sig Low active input
Gnd (floating gnd)

J5 X axis
Step to drive
Dir to drive
Com +5v for Gecko drives
Selected by J9

J7 Y axis
Step to drive
Dir to drive
Com +5v for Gecko drives
Selected by J9

J10 Z axis
Step to drive
Dir to drive
Com +5v for Gecko drives
Selected by J9

J8 A axis
Step to drive
Dir to drive
Com +5v for Gecko drives
Selected by J9

J9 com selector for drives
Jump to GND for Rutex and other drives using a common gnd.
Jump to +5c for Gecko and other drives using common +5v .

Jmp 1 charge pump MODE selector.
CP charge pump active
NCP charge pump by-passed.

J8 A axis
Step to drive
Dir to drive
Com +5v for Gecko drives
Selected by J9

J9 com selector for drives
Jump to GND for Rutex and other drives using a common gnd.
Jump to +5c for Gecko and other drives using common +5v .

Jmp 1 charge pump MODE selector.
CP charge pump active
NCP charge pump by-passed.

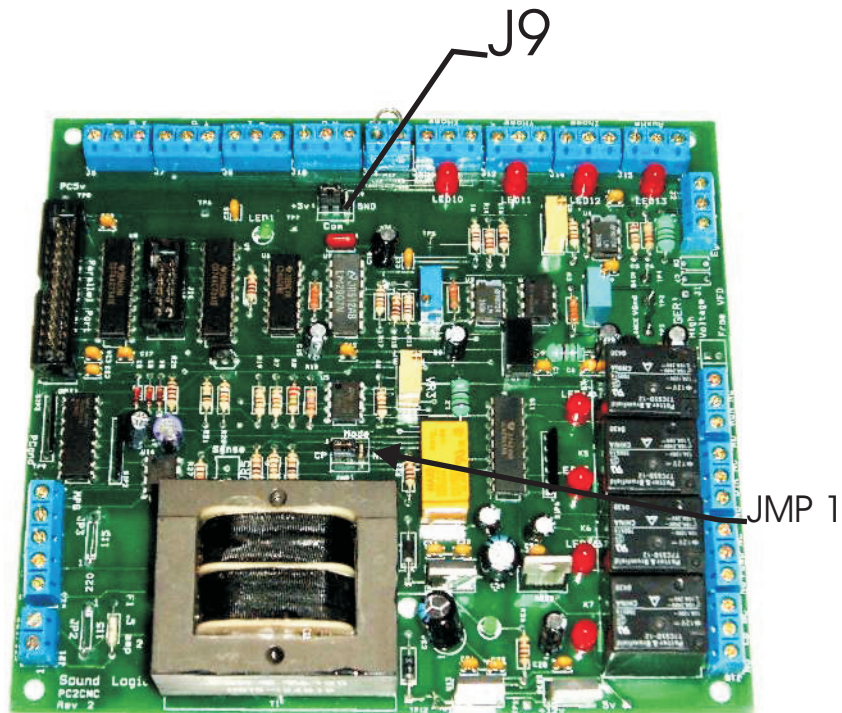

Sound Logic PC2CNC Interface

Load the **ComboM3.XML** interface XML file to configure Mach3.

Screen shot of the configuration will be provided.

1. Step and dir signals for X, Y, Z, and A axes
2. Home / Limit switch inputs for each axis
3. Spindle speed control
4. Spindle speed defaults to 3600 RPM. You may
Change in Config/Spindle page
Enter the maximum speed into the selected
Pulley.
5. Charge pump

Spindle Speed Set up

The spindle speed control accepts step and direction signals form Mach3 and converts the step signals to a 0 to 5 volt or 0 to10 volt analog (DC) signal for driving a VFD, or DC motor drive.

Warning VFDs analog in ground is not at earth potential , in fact it is often greater that 300 volts. The spindle speed control board uses an isolated power supply and an analog optical isolator to provide the necessary safety for the installer and operators well protecting the electronics.

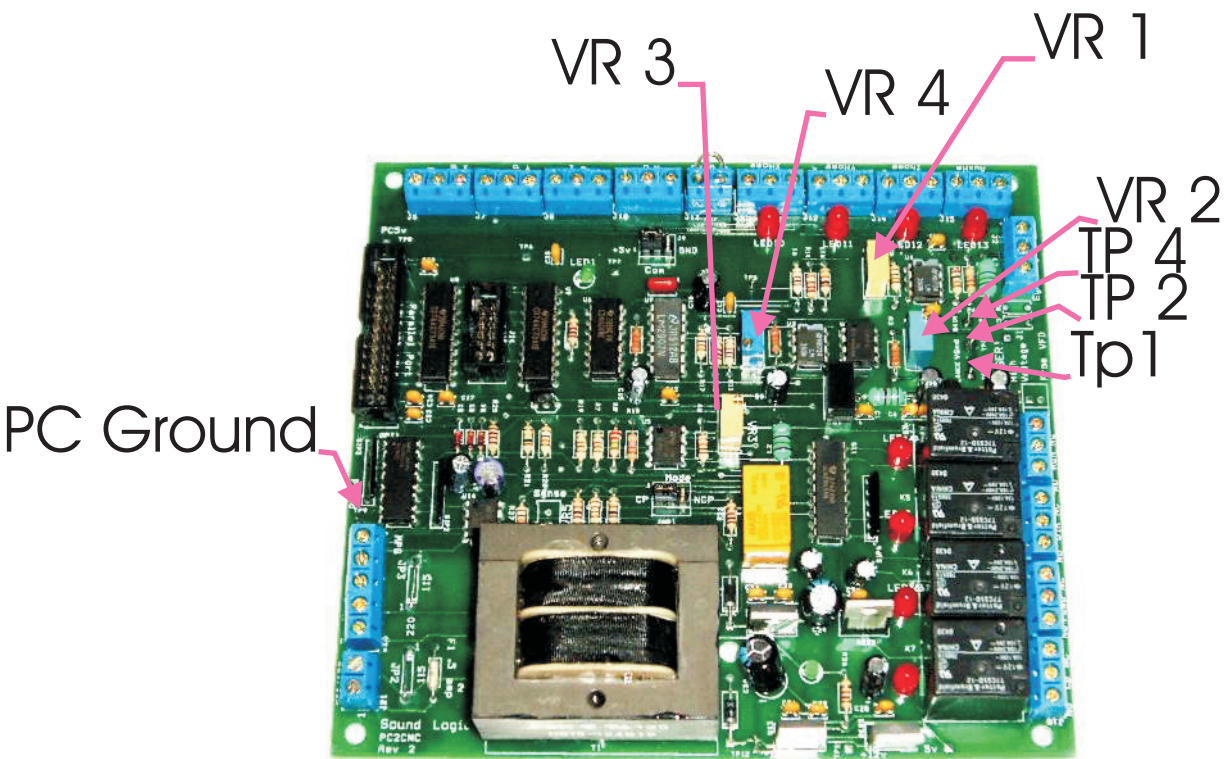

Set up and Adjustment:

The first thing to do is configure Mach3 to provide the step and direction signals on the proper pins. Mach3 also needs to be setup to output the step frequency range.

Refer to the screen shots to configure Mach3. Spindle speed screen snapshots are available for download.

Here are some of the important settings.

Ports and Pins / Port setup, Spindle setup. Under Motor control, put a check mark in “Use Spindle Motor Output”. Then check step and dir motors.

Under Pulley ratios select pulley #4. Set the minimum to 100 and the maximum to 3600. Click on Apply then OK.

The screenshot shows the 'Engine Configuration... Ports & Pins' dialog box with the 'Spindle Setup' tab selected. The dialog is divided into several sections:

- Relay Control:** Disable Spindle Relays. Clockwise (M3) Output # 1. CCW (M4) Output # 1. Output Signal #'s 1-6.
- Flood Mist Control:** Disable Flood/Mist relays. Mist M7 Output # 2. Flood M8 Output # 3. Output Signal #'s 1-6.
- ModBus Spindle - Use Step/Dir as well:** Enabled. Reg 64 64 - 127. Max ADC Count 16380.
- Motor Control:** Use Spindle Motor Output. PWM Control. Step/Dir Motor. PWMBase Freq. 7. Minimum PWM 1 %.
- General Parameters:** CW Delay Spin UP 1 Seconds. CCW Delay Spin UP 1 Seconds. CW Delay Spind DOWN 1 Seconds. CCW Delay Spin DOWN 1 Seconds. Immediate Relay off before delay.
- Pulley Ratios:** Current Pulley Set. Min Speed. Max Speed. RPM. Pulley Ratio #1 0 512. Pulley Ratio #2 0 1024. Pulley Ratio #3 0 2048. Pulley Ratio #4 100 3600.
- Special Functions:** Laser Mode. freq by Feedrate %. Use Spindle Feedback in Sync Modes. Closed Loop Spindle Control. P 0.25 I 1 D 0.3. Spindle Speed Averaging.

Buttons at the bottom: OK, Cancel, Apply.

Ports and Pins output signals, Set output #1 to port 1 pin 1. Output #2 to port 1, pin 14. Click on apply.

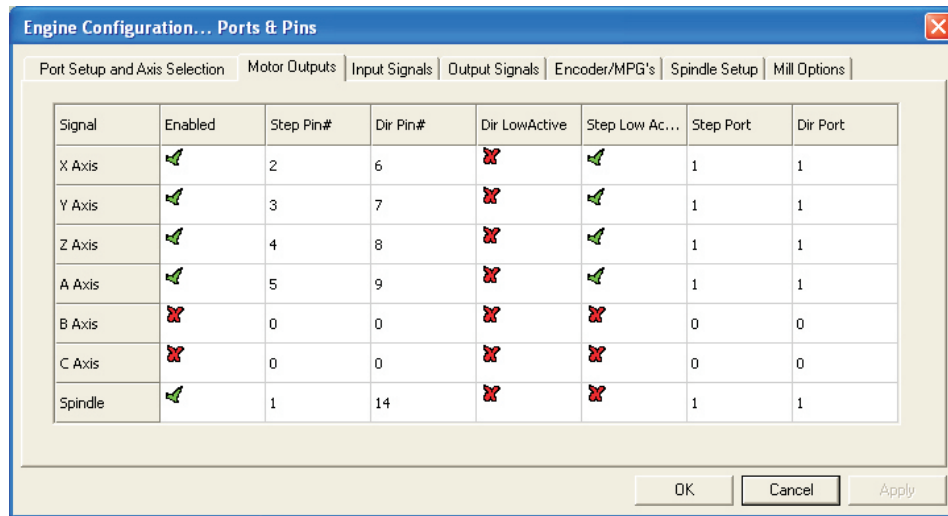

NOTE: The first two outputs are being used for the spindle speed control. This leaves you with one relay output plus the charge pump relay output.

Motor Tuning: Click on the Spindle option and set the Velocity to 60 and the steps per unit to 20,000.

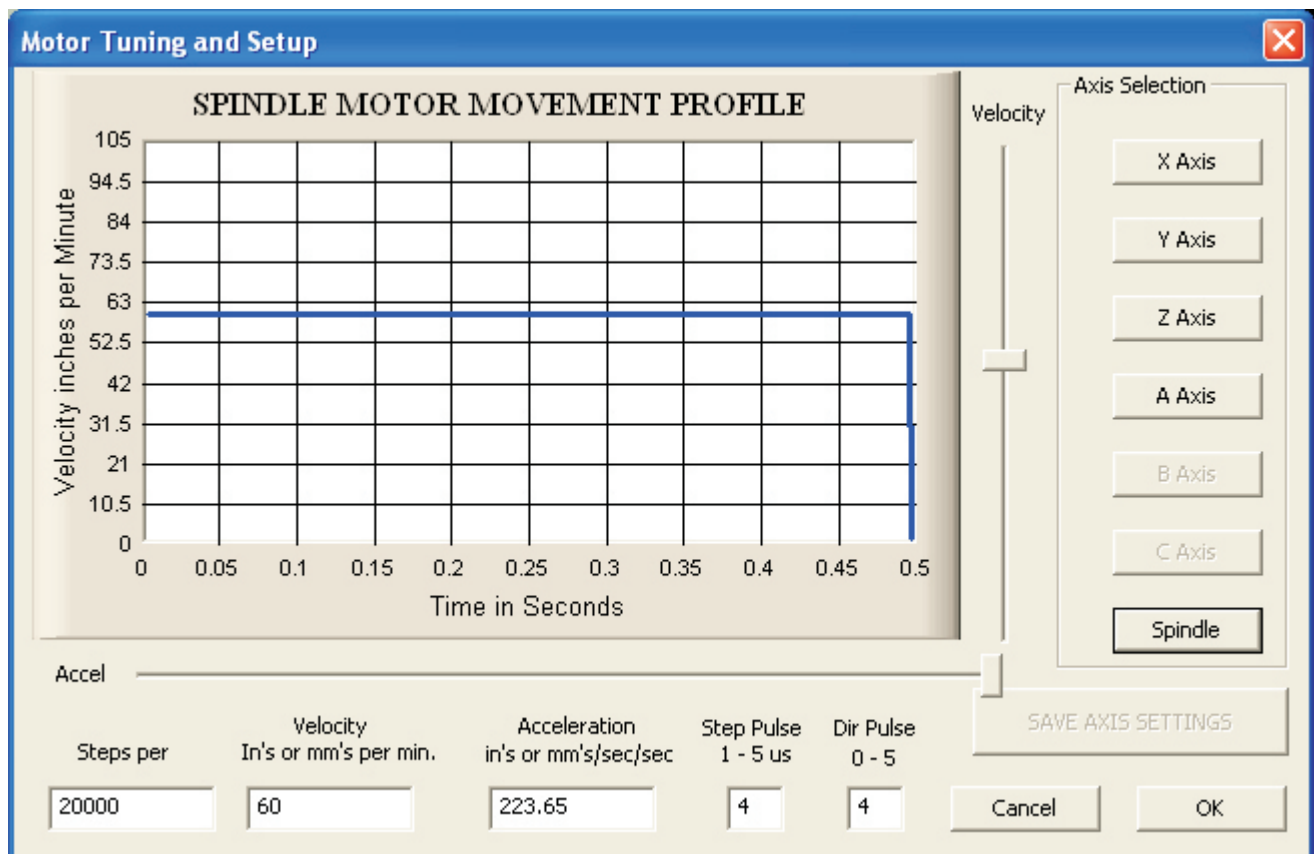

Turn the power off to the VFD.

1. Enter the Pulley Ratio four value into Mach3 spindle speed RPM DRO and press enter. (run screen shot). The example shows **3600**. For testing we used 3600. Once the spindle speed board it checked out and calibrated you can use a different spindle speed in Ratio 4 or set your maximum speed in another pulley speed and then make that pulley your current pulley.

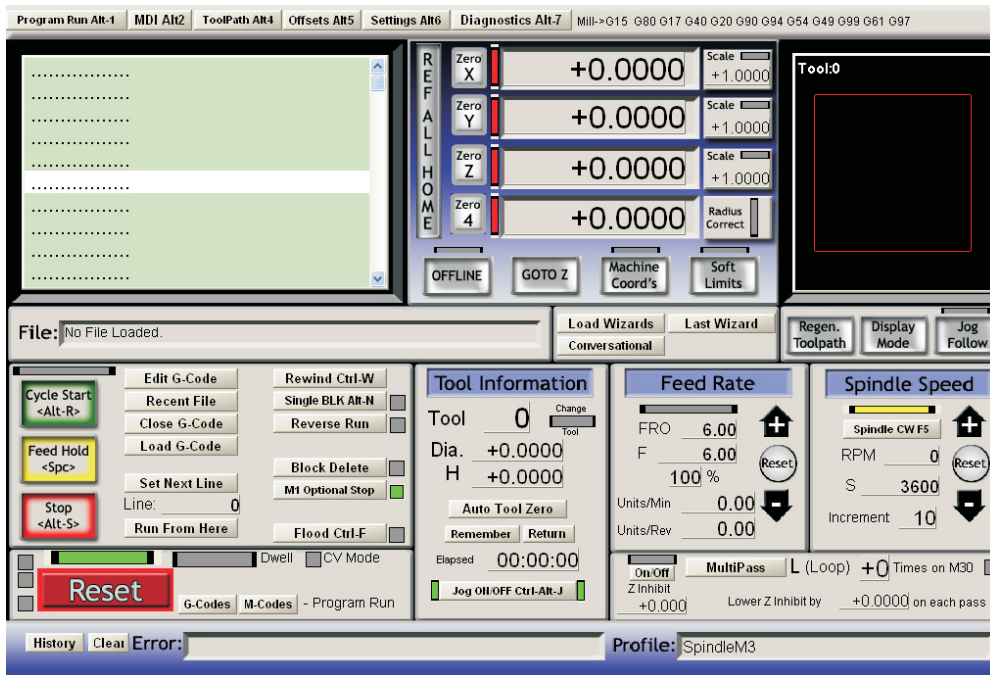

3. Clip ground lead of a Multimeter to PCgnd TP9
4. Clip Plus lead of meter to TP5 F/V
5. Toggle spindle ON
6. Adjust Vr4 for 5.0 volts
7. Move the ground lead to VFD gnd TP2 (**Turn VFD power OFF !!!**)
8. Move the Plus lead to Balance TP3
9. Adjust Vr2 to 5.0 volts
10. Move Plus Lead to Gain TP4
11. Adjust Vr1 to 5.0 volts for a 0 to 5 volts control or 10 volts for a 0 to 10 volts control

12. Set the speed DRO to 100 or the lowest speed you will use.

13. To test Dir relay, enter an M04 into the MDI DRO.

14. Adjust Vr3 CCW until the Spindle Run relay engages

15. Adjust Vr3 CW until the relay disengages

This is the low speed drop out

Remove both leads

Power off the board

Connect the VFD Use shielded wire and wire the shield to chassis. Connect on the VFD end.

Remember if your VFD is not isolated it could be as much as 200v above ground and is very dangerous and it takes several seconds to discharge.

Be Careful !!!

Power it up

Power the board

Connecting the drive:

The drive has high voltage at the connection points so BE CAREFUL and remove power from the drive!!!

There are more than one way that manufactures set there VFDs up.

The analog is simple, just connect the SPD output of the spindle speed board to the analog input of the drive. The GND will connect to the analog ground.

The direction and start/runs is where the difference is.

Some drives start as soon as they receive a direction signal , normally a FWD and REV input to the drive. Others you set the direction with the FWD and REV input that give a start/run signal.

If your drive starts to run when the direction signals are applied, install the jumper JP1 on the spindle speed control PCB. The board is normally shipped with the jumper installed.

Connections:

DIR terminal block

NC to Fwd of the drive

NO to REV of the drive

LEAVE COM OPEN. The ground to your drive will come from the Com screw terminal on the Run terminal block. Internally the Com terminal on the Dir terminal block is connected to the normally open terminal on the Run terminal block.

The Run terminal block

NC in open

NO to start or Run input to the drive

Com to the GND input of the drive

If your drive requires the start/run signal as well as the direction signal

Remove Jumper JP1 on the spindle speed control board. (place it on one of the pins to keep it with the drive PC board.

Connections:

DIR terminal block:

NC to Fwd of the drive

NO to REV of the drive

Com to the GND input of the drive

The **Run** terminal block:

NC in open

NO to start or Run input to the drive

Com to the GND input of the drive

If you find another configuration please let me know and we will help you get it wired.

The Sound Logic Spindle Speed board can be used with other breakout boards.

NOTE: The spindle speed board can be run from any breakout board that can supply power (15 to 24 VDC) to J6 and step and direction signals to J4.

External power:

J6 + = 15 to 24vdc

- = ground

External step and dir signals:

J4

Step Parallel

Gnd Parallel port ground

Dir Parallel

Test STEP and Dir

1. Power the PC and run Mach3
2. After connecting the interface to the Gecko drives.
3. Apply power the interface.
4. All of the STEP and DIR LEDs will be ON

if the Geckos are connected. All off if nothing connected.
This is a good troubleshooting tool.

5. Click on Reset
6. The out 4 LED will come ON. All the Step and Dir LEDs will be off
7. Jog the X axis by pressing the UP arrow key
The Step LED will come ON and stay on. (The pulses are too narrow to see.) If the outs are set to Active High the steps LED will glow slightly as you move the axis. For Gecko drives use Active Low.
The Dir LED will alternate ON and OFF as you alternate between the UP and Down arrow key
8. Test the other axes the same. The Y axis is the Left / right arrow
The Z axis is the page up and page down.
The A axis is the + and - keys (not shifted)

Test Home switches.

1. Connect the parallel port cable to the interface and power up the PC and start Mach3 and click on Reset. The Out 4 LED will come ON.

Jog each axis in the direction that turns on the DIR LED.

2. Select the diag page.

3. With the board powered and the home switches connected use a clip lead to momentarily connect the Sig input terminal for the X axis to the GND terminal.

4. Results: The LED by the terminal will come ON

In Mach3 note the LEDs for the Limit and Home

Are on. Mach3 will reset and the Out4 LED will go out. If Gecko drives are hooked up all LEDs will come on. If no drives are hooked up all LEDs will extinguish. Remove the jumper and the Limit / Home LED will go out.

Reset Mach3 , Out 4 LED light and the DIR LEDs will be as they were before shorting the LIMIT/ HOME input. All relays will be off except OUT 4 relay.

5. Do the same test for the Y, Z, and A axis.

NOTE:

If you use normally closed home limit switches The Home LEDs will be ON. You will need to open the connection rather than short them and the LEDs will go out. The LEDs in Mach3 will come on when the input is active whether it is Active Low or Active High

Disclaimer:

Sound Logic or James T. Cullins assumes no responsibility or liability for any damage done to persons, PC, Gecko drives, equipment being controlled, loss of time or loss of work incurred while using the PC2Route interface board, all versions.

Sound Logic
James Cullins
3454 Sprindletree Dr.
Grapevine, TX. 76051
James_cullins@sbcglobal.net

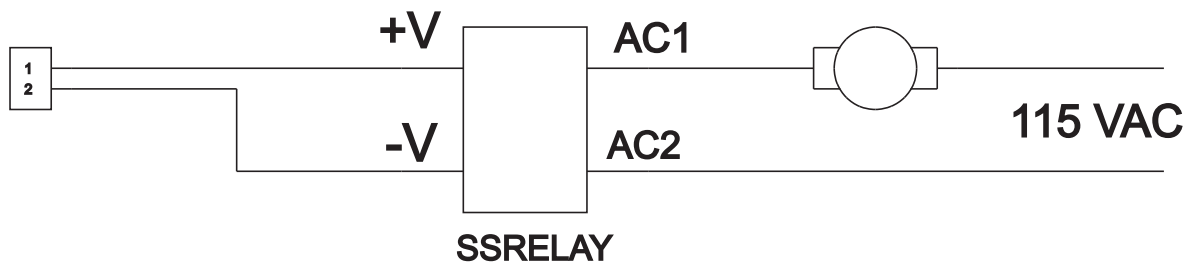

The above circuit is a sample of a solid state relay used with the pc-2-route break-out board. The break-out board provides 12 VDC to power the relay.

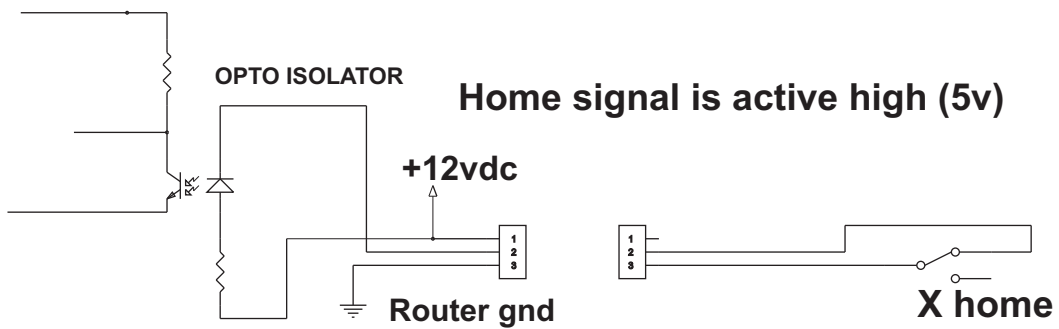

The above circuit is a sample of a micro switch being used in place of a proximity switch as a home limit switch.